

STANDARD OPERATING PROCEDURE
Sediment TOC analysis using Shimadzu TOC-Vcsn and SSM-5000A

KEY WORDS

Sediment, total organic carbon, inorganic carbon, acid, ceramic boat

APPROVALS

APPROVED BY: *Original signed by* _____ DATE: 3/4/2016

Kean S. Goh, Ph.D.
Environmental Monitoring Branch Manager I

APPROVED BY: *Original signed by* _____ DATE: 2/29/2016

Michael P. Ensminger, Ph.D.
Senior Environmental Scientist (Specialist)

APPROVED BY: *Original signed by* _____ DATE: 3/4/2016

Chang-Sook Lee Peoples
Environmental Monitoring Branch Quality Assurance Officer

PREPARED BY: *Original signed by* _____ DATE: 2/29/2016

Korena L. Goodell
Scientific Aide

Environmental Monitoring Branch organization and personnel, such as management, senior scientist, quality assurance officer, project leader, etc., are defined and discussed in SOP ADMN002.

STANDARD OPERATING PROCEDURE

Sediment TOC analysis using Shimadzu TOC-Vcsn and SSM-5000A

1.0 INTRODUCTION

1.1 Purpose

The Shimadzu TOC-V analyzer and the SSM-5000A (solid sample combustion unit) are used to measure total organic carbon in solid samples.

1.2 Definitions

Total Organic Carbon (TOC) is a measure of the amount of organic carbon after inorganic carbon has been removed.

2.0 MATERIALS

2.1 TOC-VCSN analyzer

2.2 SSM-5000A solid combustion unit

2.3 Plastic weigh boats

Medium size with spout recommended

2.4 Ceramic sediment boats

Shimadzu part number 630-02679-00

2.5 Sediment sample(s)

2.6 Fructose, a certified sediment standard, and sodium bicarbonate

2.7 Ceramic fiber

Shimadzu part number 638-60074-00

2.8 TOC Certified water <100ppb

Shimadzu part number 220-95236-02

2.9 Deionized (DI) water

2.10 Phosphoric acid (H₃PO₄)

2.11 Hydrochloric acid (HCl)

2.12 Bunsen burner

STANDARD OPERATING PROCEDURE

Sediment TOC analysis using Shimadzu TOC-Vcsn and SSM-5000A

2.13 Spatulas

2.14 Tongs or tweezers

2.15 Analytical balance

3.0 PROCEDURES

3.1 Equipment Check

- 3.1.1 Wear gloves before proceeding. Open the front door of the TOC-VCSN using the latch on the bottom left. Check the **drain vessel** volume (back of machine, right hand side). If needed, fill with DI water to the level indicated by the drain discharge tube on the side of the container. Use DI wash bottle to fill the container through the slits in the top of the black cap in situ. **Do not** remove the cap or unclip the bottle from its current location. Use Figure 1 as a reference; see Figure 2 for a close-up view.
- 3.1.2 With the door open, check the **humidifier** water container level in the front of the TOC-VCSN; fill if needed. Add **TOC certified water** using a wash bottle to fill the container to the 'Hi' level mark. Squirt water through the water supply port opening in the top of the container. Close the door of the TOC-VCSN (Figure 2).
- 3.1.3 Monitor the **printer paper** by removing the cover to the paper roll. Replace the paper roll if necessary.
- 3.1.4 On the side of the SSM-5000A, fill the drain vessel with DI water to the level of the drain discharge tube on the side of the drain vessel (Figure 3).

3.2 Turning on the TOC-V

- 3.2.1 Press the "Power" button located in the lower right hand corner to power on the TOC-VCSN (Figure 4). It will take 20 to 30 min to reach operating temperature. The TOC-VCSN is at the correct operating temperature when the green light below the **ready** signage on the keypad is steady green (not flashing).

STANDARD OPERATING PROCEDURE

Sediment TOC analysis using Shimadzu TOC-Vcsn and SSM-5000A

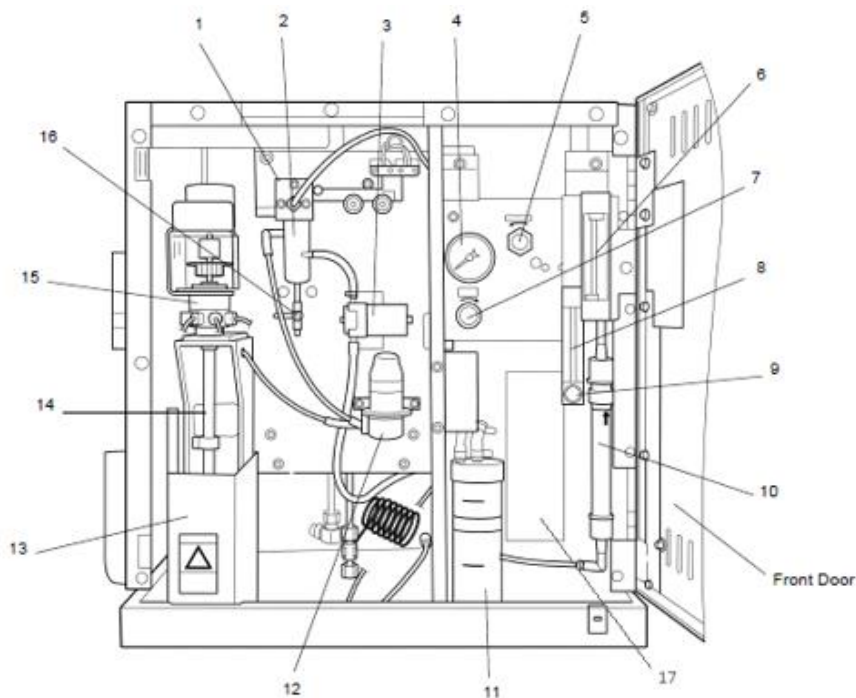

Figure 1. Layout of the TOC-V_{CSN/H} after opening the front door of machine.

- 1) Sliding sample injector (TOC-V_{CSH} only)
- 2) IC reagent vessel (TOC-V_{CSH} only)
- 3) Solenoid valve (for IC drainage) (TOC-V_{CSH} only)
- 4) Carrier gas pressure gauge
- 5) Carrier gas flow adjustment knob
- 6) Carrier gas flowmeter
- 7) Carrier gas pressure adjustment knob
- 8) Sparge gas flowmeter (TOC-V_{CSH} only)
- 9) Sparge gas flow adjustment knob (TOC-V_{CSH} only)
- 10) Halogen scrubber
- 11) Humidifier
- 12) Pump (for IC reagent supply) (TOC-V_{CSH} only)
- 13) Syringe pump cover
- 14) 5 mL syringe
- 15) 8-port valve
- 16) 3-way valve
- 17) Drain vessel

STANDARD OPERATING PROCEDURE
Sediment TOC analysis using Shimadzu TOC-Vcsn and SSM-5000A

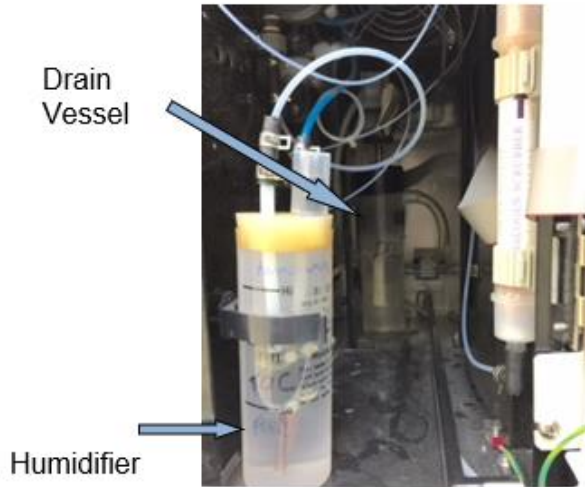

Figure 2. TOC-VCSN

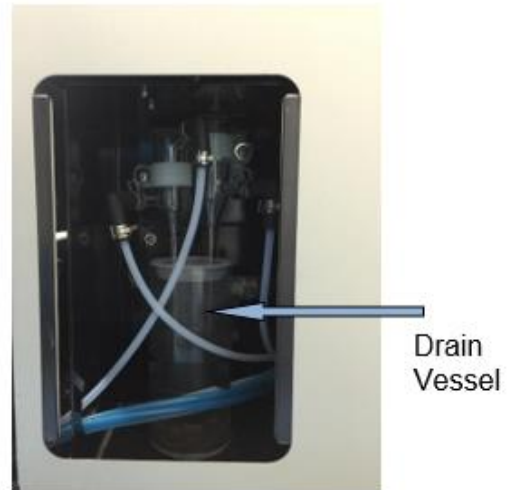

Figure 3. SSM-5000A



Figure 4. TOC-VCSN machine

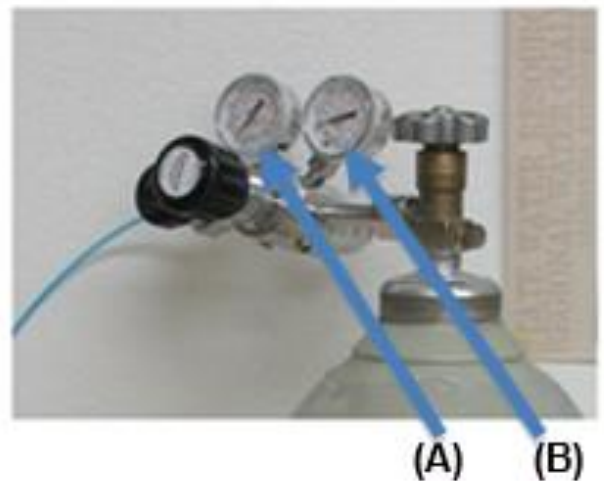

Figure 5. Oxygen tank; gas pressure (A) and tank volume (B)

STANDARD OPERATING PROCEDURE

Sediment TOC analysis using Shimadzu TOC-Vcsn and SSM-5000A

- 3.2.2 Immediately after turning the machine on, supply oxygen to TOC-VCSN by turning the metal knob on the **oxygen tank** counter-clockwise. Use the two gauges on the top of the tank to regulate the amount of oxygen available to the TOC-VCSN. The right gauge measures the amount of O₂ gas in the tank whereas the left gauge regulates the pressure of the gas entering the TOC-VCSN (Figure 5). The needle of the left gauge should be between 44-87 psi; **60 psi** is the optimum operating pressure. If the needle of the right gauge is below 200 psi, there may not be enough O₂ to properly conduct an analysis and the oxygen tank should be replaced.
- 3.2.3 Open the front door of the machine and adjust the two carrier gas regulators (Figure 6). The round **carrier gas flow pressure regulator** is located on the left hand side of the TOC-VCSN. Use the knob below the gauge to adjust the carrier gas pressure to **200 KPa**. The long rectangular **carrier gas flow meter** is located on the right hand side. Adjust the carrier flow using the carrier gas knob to the left of the gauge. The bottom of the ball should be level to the 150 mL/min increment in the scale. Close door.



Figure 6. Setting the carrier gas pressure and flow.

STANDARD OPERATING PROCEDURE

Sediment TOC analysis using Shimadzu TOC-VcsN and SSM-5000A

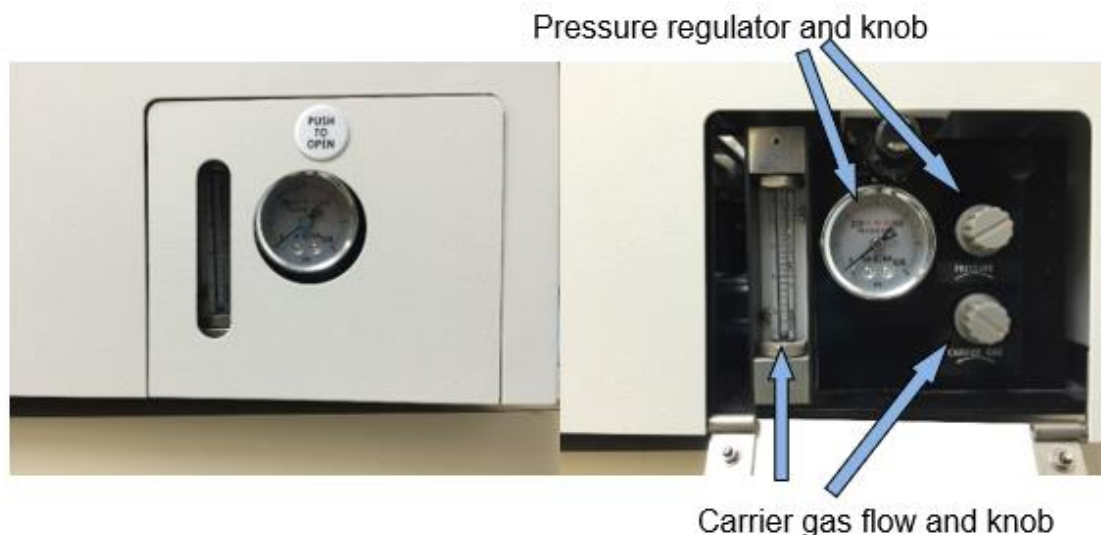

Figure 7. Side panel of SSM-5000A and location of carrier gas and pressure regulation knobs.

3.3 Turning on SSM-5000A machine

- 3.3.1 Turn on the power button on the right-hand side of the SSM-5000A machine. The SSM-5000A will take about 20-30 min to reach operating temperature. The **green ready light** will be steady (not flashing) once operating temperature is reached.
- 3.3.2 On the front of the SSM-5000A, check the carrier gas pressure to ensure that it is at 200 kPa (Figure 7). Adjust it using the **pressure regulation knob** if necessary.
- 3.3.3 Check that the carrier flow rate is at 0.5mL/min; if necessary, adjust it using the **carrier gas knob** (Figure 7).

3.4 Setting Parameters on the TOC-V Conditions Screen (F4)

- 3.4.1 Arrow down to set the **SSM measurement, SSM-TC furnace, and SSM-IC furnace** to **ON** using the **select** key. On the SSM-5000A, set the TC furnace to 900°C and IC furnace to 200°C (Figure 8).

STANDARD OPERATING PROCEDURE
Sediment TOC analysis using Shimadzu TOC-Vcsn and SSM-5000A

- 3.4.2 Set the **cell length** to **short** unless conducting high sensitivity measurements.
- 3.4.3 Under the **meas cond (F4)** screen, select the output unit using the select key. For sediment samples, % C is preferred.
- 3.4.4 Press **F1** to return to the main screen.

Conditions																					
<table border="1"> <tr> <td colspan="2">Basic Unit</td> </tr> <tr> <td>Furnace</td> <td>:ON</td> </tr> <tr> <td>Power</td> <td></td> </tr> <tr> <td>Temp</td> <td>:680 °C</td> </tr> </table>	Basic Unit		Furnace	:ON	Power		Temp	:680 °C	<table border="1"> <tr> <td colspan="2">Printer</td> </tr> <tr> <td>Routine Report</td> <td>:ON</td> </tr> <tr> <td>Peak Print</td> <td>:OFF</td> </tr> <tr> <td>Cal.Grp.Print</td> <td>:ON</td> </tr> </table>	Printer		Routine Report	:ON	Peak Print	:OFF	Cal.Grp.Print	:ON				
Basic Unit																					
Furnace	:ON																				
Power																					
Temp	:680 °C																				
Printer																					
Routine Report	:ON																				
Peak Print	:OFF																				
Cal.Grp.Print	:ON																				
<table border="1"> <tr> <td>Catalyst Type</td> <td>:Regular</td> </tr> </table>	Catalyst Type	:Regular																			
Catalyst Type	:Regular																				
<table border="1"> <tr> <td colspan="2">TN</td> </tr> <tr> <td>Power</td> <td></td> </tr> </table>	TN		Power		<table border="1"> <tr> <td colspan="2">ASI</td> </tr> <tr> <td>Vial</td> <td>:40ml</td> </tr> <tr> <td>Needle Set</td> <td>:Sampling</td> </tr> <tr> <td>Needle Rinse</td> <td>:ON</td> </tr> <tr> <td>Needle Rinse after acid add</td> <td>:ON</td> </tr> <tr> <td>Stirrer</td> <td>:ON</td> </tr> <tr> <td>Flowline wash A</td> <td>:1</td> </tr> <tr> <td>Flowline wash B</td> <td>:2</td> </tr> </table>	ASI		Vial	:40ml	Needle Set	:Sampling	Needle Rinse	:ON	Needle Rinse after acid add	:ON	Stirrer	:ON	Flowline wash A	:1	Flowline wash B	:2
TN																					
Power																					
ASI																					
Vial	:40ml																				
Needle Set	:Sampling																				
Needle Rinse	:ON																				
Needle Rinse after acid add	:ON																				
Stirrer	:ON																				
Flowline wash A	:1																				
Flowline wash B	:2																				
<table border="1"> <tr> <td colspan="2">SSM</td> </tr> <tr> <td>SSM Measurement</td> <td>:ON</td> </tr> <tr> <td>SSM-TC Furnace</td> <td>:ON</td> </tr> <tr> <td>SSM-IC Furnace</td> <td>:ON</td> </tr> <tr> <td>Cell Length</td> <td>:Short</td> </tr> </table>	SSM		SSM Measurement	:ON	SSM-TC Furnace	:ON	SSM-IC Furnace	:ON	Cell Length	:Short											
SSM																					
SSM Measurement	:ON																				
SSM-TC Furnace	:ON																				
SSM-IC Furnace	:ON																				
Cell Length	:Short																				
<table border="1"> <tr> <td colspan="2">Other Units</td> </tr> <tr> <td>ESU</td> <td>:Disable</td> </tr> <tr> <td>SP Kit</td> <td>:Disable</td> </tr> <tr> <td>Manual Inj:</td> <td>:Disable</td> </tr> </table>	Other Units		ESU	:Disable	SP Kit	:Disable	Manual Inj:	:Disable													
Other Units																					
ESU	:Disable																				
SP Kit	:Disable																				
Manual Inj:	:Disable																				

Figure 8. Conditions key (F4) selected and parameters. Select the F4 key again to change to Measurement Conditions.

STANDARD OPERATING PROCEDURE

Sediment TOC analysis using Shimadzu TOC-Vcsn and SSM-5000A

4.0 CONDUCTING ANALYSIS USING TOC SSM-5000A

4.1 Testing standards for total carbon (TC)

- 4.1.1 Prior to conducting analyses, wear gloves and use tweezers to work with the boats. Always place a weigh boat on the balance pan prior to weighing samples to protect the analytical balance and for ease of clean up.
- 4.1.2 Run two carbon standards for QC: fructose (or other high carbon source used to make calibration curve) and a certified sediment standard.
- 4.1.3. Weigh out QC standards on an analytical balance. Place a ceramic boat on the balance and tare. Once tared, weigh out about 50 mg of fructose or up to 150 mg of the sediment standard. Less fructose is weighed because it contains a high carbon concentration (40%) and more than 30 mg of carbon released during analysis will adversely affect the carbon analyzer.
- 4.1.4 Using tweezers, remove boat from the balance. Gently tap the ceramic boat to evenly distribute the sample (Figure 9).

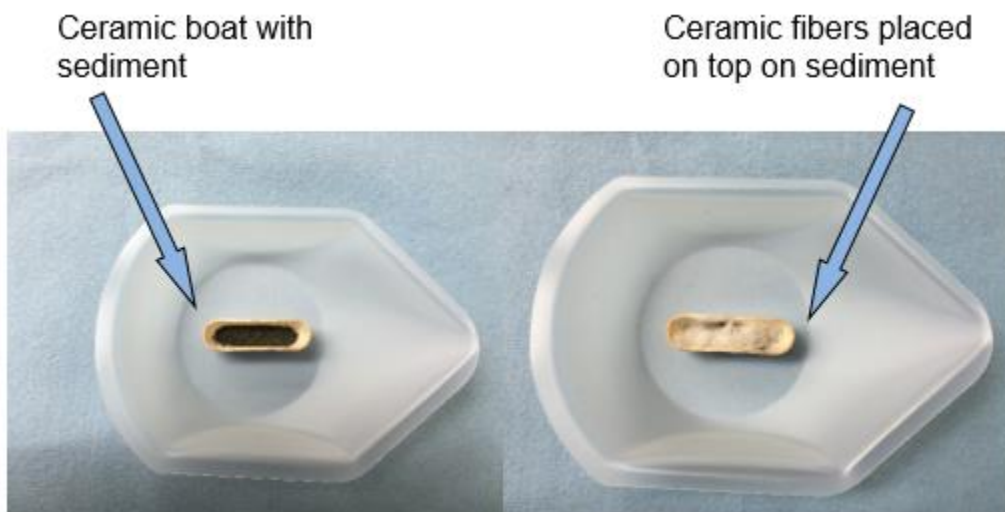

Figure 9. Left image shows the ceramic boat with sediment sample. Right image shows ceramic fibers placed on top of sediment sample.

STANDARD OPERATING PROCEDURE

Sediment TOC analysis using Shimadzu TOC-VcsN and SSM-5000A

- 4.1.5 Using tweezers, place ceramic fiber on top of sample (Figure 9) this will prevent splattering in the TC chamber of the SSM-5000.
- 4.1.6 Place the sample into the TC injection port and close the chamber. Let sit for about three minutes so ambient air (CO₂) can escape and not skew the results.
- 4.1.7 Ensure that the IC injection chamber is sealed; IC chamber tubing is connected to the TC chamber tubing.
- 4.1.8 During this time, press the **measure sample** button on the keypad. Select **TC** by pressing **F2** and input sample name by using **shift** button to type in letters; press enter to complete. Then press the **down arrow** to select the appropriate calibration curve and select curve number.
- 4.1.9 Press **next** and enter weight.
- 4.1.10 After three minutes, once the ready light has been solid green for a few seconds and the start button flashing, simultaneously press **start** and push the blue tab from the **sample change position** to the **measuring position**.
- 4.1.11 Once the sample is finished, the screen will direct you to pull the blue tab to the **cooling position** then back to the **sample change position**.
- 4.1.12 Open the chamber and, with caution, remove the boat using tweezers. The ceramic boat is extremely hot so place it on a heat resistance surface.
- 4.1.13 If results of the standards are not within 10% of the standard's true value, then conduct another analysis. If consistently out of range, a new concentration curve may be needed, or the machine may need servicing. For conducting calibrations, refer to DPR SOP METH011.

4.2 Testing calibration standards inorganic carbon (IC)

- 4.2.1 Measure out 50-150 mg of sodium hydrogen carbonate (NaHCO₃) or other appropriate inorganic carbon source.

STANDARD OPERATING PROCEDURE

Sediment TOC analysis using Shimadzu TOC-Vcsn and SSM-5000A

- 4.2.2 Gently tap the ceramic boats to evenly distribute the samples.
- 4.2.3 Open the IC port and gently insert the sample using tweezers. Note that ceramic fibers are not placed over the sample. Close the chamber and let rest for about three minutes.
- 4.2.4 During this time press **measure sample** on the keypad and select **F3** for **IC**; press **F2** to minimize **TC**. Input sample name and press enter. Select appropriate calibration curve and press next; enter sample weight.
- 4.2.5 After three minutes, check that the ready light is green and the start button is blinking. When ready, lift the acid pump and slowly inject up to 0.5 ml of 25% phosphoric acid into the sample. Simultaneously, press start and push the green tab from **sample change position** to the **measuring position**.
- 4.2.6 To make a 25% stock solution of phosphoric acid, add 73.5 ml of 85% phosphoric acid to a final volume of 250 ml. Always add acid to water; use certified low TOC water for the solution.
- 4.2.7 The screen will prompt you to pull the tab back to **sample change position**. Carefully open the chamber and remove the ceramic boat with tweezers. Place it on a heat resistant surface.
- 4.2.8 Clean up the acid residue from around the lip of the chamber. Use tweezers and Kimwipes™.

STANDARD OPERATING PROCEDURE

Sediment TOC analysis using Shimadzu TOC-Vcsn and SSM-5000A

4.3 Standard Specifications

The following specification guidelines are recommended for selected organic and inorganic standards. Warnings are within 10% of the standard and unacceptable is $\geq 25\%$.

Standard Type	Substance	Carbon content	Low unacceptable	Low warning	High warning	High unacceptable
Total carbon	Fructose	40.0%	31.1%	36.2%	44.2%	51.5%
Total carbon	Marine sediment	3.36%	2.6%	3.0%	3.7%	4.3%
Inorganic carbon	Sodium hydrogen bicarbonate (Na ₂ HCO ₃)	14.3%	10.7%	12.9%	15.7%	17.9%
Inorganic carbon	Sodium bicarbonate (Na ₂ CO ₃)	11.3%	8.5%	10.2%	12.4%	14.1%

5.0 TESTING SAMPLES

5.1 As described in Section 4.1, weigh out sediment sample. Measure 50-150 mg of sediment per ceramic boat, dependent on expected carbon content.

5.2 For QC, it is recommended to run three reps, with a CV of $\leq 10\%$. After the first ceramic boat has been removed from the injection port, refer back to the screen and press **add injection (F1)** to measure multiple reps of the same sample.

5.3 Both TC and IC analysis can be selected for one sample.

5.4 If necessary, the result of a rep can be removed by pressing the **EXC** (exclude) key.

5.5 After TC analysis has been completed, refer back to the screen and press **go to next analysis (F6)** to change analysis type to IC.

5.6 When TC and IC analysis are completed, press **exit analysis (F6)** to end the analysis.

6.0 POWERING OFF TOC-VCSN AND SSM-5000A

6.1 On initial display

STANDARD OPERATING PROCEDURE

Sediment TOC analysis using Shimadzu TOC-Vcsn and SSM-5000A

- 6.1.1 Press the **F1 (stand by option)** key
- 6.1.2 Press **F5 (power off)** key
- 6.1.3 Press **F6 (execute)** key to turn off the TOC-VCSN machine. For automatic shutdown press **yes (F6), this is a termination.**
- 6.1.4 After 30 minutes the TOC-VCSN automatically turns off.
- 6.1.5 After the SSM-5000A machine has reached ambient temperature, turn off by pressing the switch on the side.
- 6.1.6 Lastly, shut off the oxygen tank.

7.0 CLEAN UP

7.1 Cleaning ceramic boats

- 7.1.1 When cool, dispose of dry materials in the trash bin and wet materials in the sink.
- 7.1.2 Rinse the ceramic boats with tap water and brush off any debris. Scrub out inside of boat with a brush (as a toothbrush). Rinse boats with low TOC certified water.
- 7.1.3 Carefully submerge the ceramic boats into a **3N HCl solution** for ~15min.
- 7.1.4 Remove boats from HCl solution with long tweezers and rinse with TOC certified water.
- 7.1.5 Invert boats on metal slotted tray to dry.
- 7.1.6 When dry, briefly heat boats over the gas flame generated by a Bunsen burner. Heat with long tweezers to avoid burns.
- 7.1.7 Place boats in **TOC free** container.

7.2 Cleaning Tweezers and Spatulas

- 7.2.1 Rinse tools with tap water and scrub off any debris, then rinse with TOC certified water.

STANDARD OPERATING PROCEDURE

Sediment TOC analysis using Shimadzu TOC-Vcsn and SSM-5000A

7.2.2 Let tools dry then heat the tips using the Bunsen burner. Heat with long tweezers to avoid burns.

7.2.3. Place tools in a **TOC free** container.

8.0 REMEDIAL ACTION IN CASE OF MALFUNCTION

For minor problems, visit Shimadzu's TOC Advisor at <https://tocvva.ssi.shimadzu.com/>. For additional help contact a Shimadzu sales rep at http://www.ssi.shimadzu.com/about/aboutssi_id8.cfm.

9.0 SAFETY

9.1 Wear gloves for personal protection and to prevent sample contamination.

9.2 Wear closed toe shoes when conducting TOC analysis.

9.3 Wear safety glasses with side shields or goggles for eye protection when using phosphoric or hydrochloric acid.

9.4 Ensure the oxygen tanks are secured to the wall.

9.5 Do not touch hot components or open housing when unit is in use.

10.0 REFERENCES

DPR SOP METH011.00. Water TOC Analysis Using the Shimadzu TOC-VCSN and ASI-V Autosampler at <http://cdpr.ca.gov/docs/emon/pubs/sops/meth01100.pdf>

TOC Operating Conditions. 2016. ProjectZZ at <http://manualzz.com/doc/6598368/toc-operation-instructions>

Total Organic Carbon Analysis for Sediment.
<https://www.youtube.com/watch?v=G8pINBgyHF8>